

# PARANCO ELETTRICO A CATENA

Serie KF - Tipo KF/3  
Con carrello elettrico

- Alimentazione 230-400V / 50-60Hz
- Apparecchiatura in bassa tensione 48 V
- Protezione paranco IP 54
- Catena zincata resistente alla fatica e alla corrosione
- Sacco raccogli catena
- Ruote carrello su cuscinetti lubrificati a vita
- Carico sempre distribuito sulle 4 ruote poiché le piastre ruotano sul perno del carrello
- Staffe antiscarruolamento
- Respingenti in gomma
- Idonei a scorrere su travi ad ali piatte o inclinate grazie al profilo delle ruote

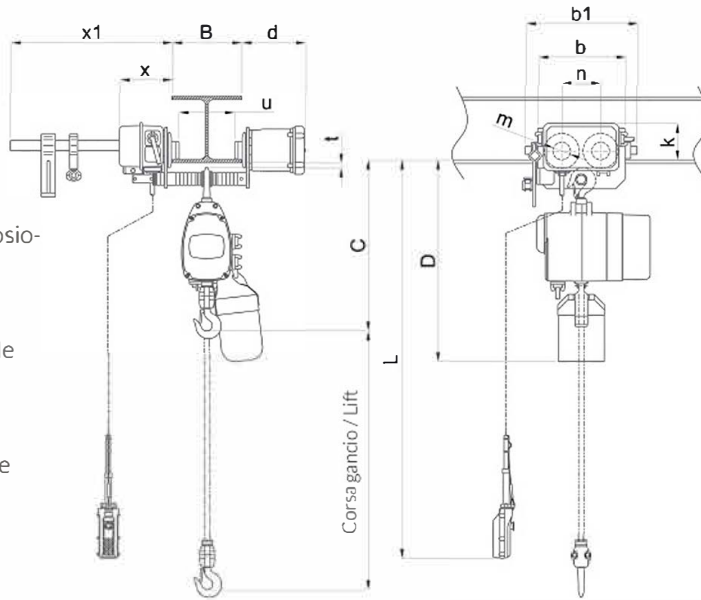

	Portata t	Tipo	Corsa gancio STD m	Cavo pulsantiera STD L m	Velocità sollevamento 50 Hz m/min.	Motore sollevamento		Velocità traslazione 50 Hz m/min.	Motore traslazione		Larghezza trave B		Raggio minimo curvatura mm	Peso netto Kg
						Potenza kW	R.I. %		Potenza kW	R.I. %	Standard mm	Option mm		
1 vel. sollev. 1 speed	125 kg	KF 20S1/3	3.0	2.5	8.0	0.45	50	10 o 20	0.10 o 0.30	40	58÷127	128÷305	1500	56
	250 kg	KF 20S2/3	3.0	2.5	4.0	0.45	50	10 o 20	0.10 o 0.30	40	58÷127	128÷305	1500	60
	250 kg	KF 25S1/3	3.0	2.5	8.0	0.45	50	10 o 20	0.10 o 0.30	40	58÷127	128÷305	1500	56
	500 kg	KF 25S2/3	3.0	2.5	4.0	0.45	50	10 o 20	0.10 o 0.30	40	58÷127	128÷305	1500	60
	500 kg	KF 50S1/3	3.0	2.5	7.0	0.80	50	10 o 20	0.10 o 0.30	40	58÷127	128÷305	1500	69
	1	KF 50S2/3	3.0	2.5	3.5	0.80	50	10 o 20	0.10 o 0.30	40	58÷153	154÷305	1500	80
	1	KF 100S1/3	3.0	2.5	6.5	1.50	50	10 o 20	0.10 o 0.30	40	58÷153	154÷305	1500	90
2 vel. sollev. 2 speed	2	KF 100S2/3	3.0	2.5	3.3	1.50	50	10 o 20	0.15 o 0.40	40	100÷178	179÷305	2000	112
	125 kg	KF 20S1A/3	3.0	2.5	8.0/2.7	0.45/0.15	40/40	10 o 20	0.10 o 0.30	40	58÷127	128÷305	1500	56
	250 kg	KF 20S2A/3	3.0	2.5	4.0/1.3	0.45/0.15	40/40	10 o 20	0.10 o 0.30	40	58÷127	128÷305	1500	60
	250 kg	KF 25S1A/3	3.0	2.5	8.0/2.7	0.45/0.15	40/40	10 o 20	0.10 o 0.30	40	58÷127	128÷305	1500	56
	500 kg	KF 25S2A/3	3.0	2.5	4.0/1.3	0.45/0.15	40/40	10 o 20	0.10 o 0.30	40	58÷127	128÷305	1500	60
	500 kg	KF 50S1A/3	3.0	2.5	7.0/2.3	0.80/0.27	40/40	10 o 20	0.10 o 0.30	40	58÷127	128÷305	1500	69
	1	KF 50S2A/3	3.0	2.5	3.5/1.2	0.80/0.27	40/40	10 o 20	0.10 o 0.30	40	58÷153	154÷305	1500	80
2 speed	1	KF 100S1A/3	3.0	2.5	6.5/2.2	1.50/0.50	40/40	10 o 20	0.10 o 0.30	40	58÷153	154÷305	1500	91
	2	KF 100S2A/3	3.0	2.5	3.3/1.1	1.50/0.50	40/40	10 o 20	0.15 o 0.40	40	100÷178	179÷305	2000	113

• Tutti i modelli sono disponibili con comando diretto o in bassa tensione. Su richiesta carrelli per raggi di curva inferiori.

	Portata t	Tipo	Ingombro minimo C mm	Dimensioni											
				D mm	b mm	b1 mm	d mm	g mm	k mm	m mm	n mm	t mm	u mm	x mm	x1 mm
1 vel. sollev. 1 speed	125 kg	KF 20S1/3	550	650 [740]	276	355	201	24	115	56	123	24	B-45	165	510
	250 kg	KF 20S2/3	590	650 [740]	276	355	201	24	115	56	123	24	B-45	165	510
	250 kg	KF 25S1/3	550	650 [740]	276	355	201	24	115	56	123	24	B-45	165	510
	500 kg	KF 25S2/3	590	650 [740]	276	355	201	24	115	56	123	24	B-45	165	510
	500 kg	KF 50S1/3	600	790 [870]	276	355	201	34	115	56	123	24	B-45	165	510
	1	KF 50S2/3	685	810 [890]	306	385	203	31	111.5	63	136	23	B-49	167.5	510
	1	KF 100S1/3	675	915 [955]	306	385	203	31	111.5	63	136	23	B-49	167.5	510
2 vel. sollev. 2 speed	2	KF 100S2/3	860	1030 [1070]	342	395	236	37	124.5	75	150	31	B-56	171.5	510
	125 kg	KF 20S1A/3	550	650 [740]	276	355	201	24	115	56	123	24	B-45	165	510
	250 kg	KF 20S2A/3	590	650 [740]	276	355	201	24	115	56	123	24	B-45	165	510
	250 kg	KF 25S1A/3	550	650 [740]	276	355	201	24	115	56	123	24	B-45	165	510
	500 kg	KF 25S2A/3	590	650 [740]	276	355	201	24	115	56	123	24	B-45	165	510
	500 kg	KF 50S1A/3	600	790 [870]	276	355	201	34	115	56	123	24	B-45	165	510
	1	KF 50S2A/3	685	810 [890]	306	385	203	31	111.5	63	136	23	B-49	167.5	510
2 speed	1	KF 100S1A/3	675	915 [955]	306	385	203	31	111.5	63	136	23	B-49	167.5	510
	2	KF 100S2A/3	860	1030 [1070]	342	395	236	37	124.5	75	150	31	B-56	171.5	510

• Le dimensioni ( ) della quota 'D' è riferita a paranchi con sacco raccogli catena grande.